



# SHERMAC

Engineered Equipment  
Transitions



## MULTISERVE SERVICE TRAILERS

## EXPERIENCE THAT'S DRIVING A NEW ERA IN VEHICLE ENGINEERING

At Shermac, we've been engineering and manufacturing custom service vehicles and water cartage vehicles for Australia's mining, civil and construction sectors since 2002.

We've earned a deserved reputation for excellence among heavy industry and government organisations alike. But it's not purely the quality, reliability and functionality of our high-performance vehicles that have driven our ongoing growth and the evolution of our range.

Nor is it simply our design, engineering and manufacturing expertise.

It's more fundamental than that.

Listening, evolving, solving.  
The most crucial skill in our proven engineering process is the ability to listen and build relationships.

This is what underpins our expertise in designing and delivering cost-effective, quality-assured solutions that drive performance capacity and add tangible operational and strategic value.

It's the foundation of our global sourcing and procurement network, which gives our clients access to the largest range of high quality products at the lowest fleet and bulk-purchasing prices.

And it's why we now have three distinct divisions, each dedicated to meeting the unique needs of different industries across Australia.

“  
*Our new service trailer is an absolute winner, with field maintenance enjoying the reduced scheduled service times as a result of a well prepared unit*

“  
*The trailers make us look more professional, and because they have everything on board, it allows the team to complete services quickly, safely and without mess*

“  
*It's a much cleaner and easier way to work. Environmentally, this solution reduces the risk of spillage and contamination that may occur when working out of drums*

“  
*Thank you and your team for an outstanding job on the trailer. I am very impressed with the finish and set up of the trailer. It will be a head turner where ever I go from now on*

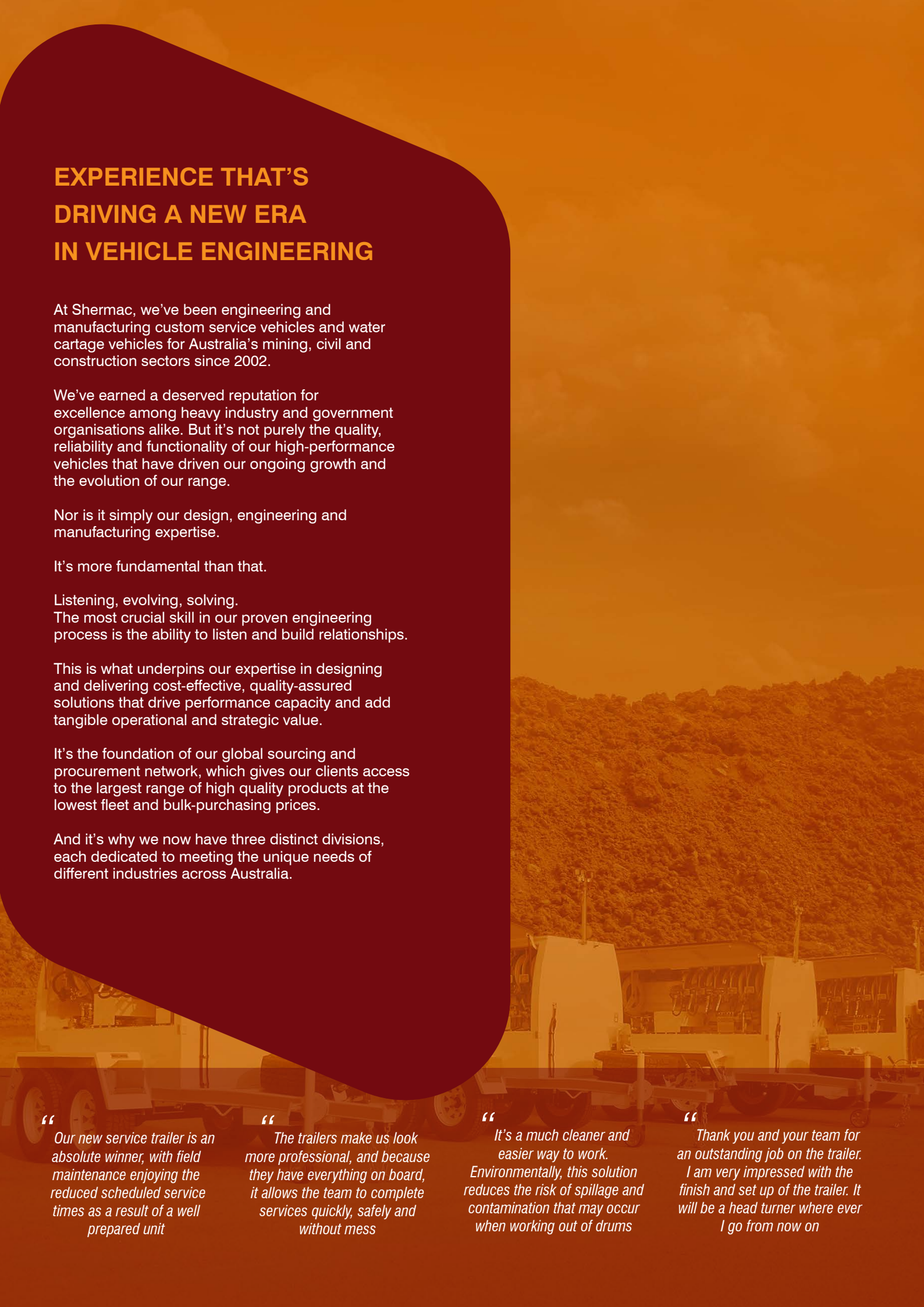

## TOUGH, SMART, SAFE AND GREAT VALUE.

Shermac have been designing and building industry-spec service trailers for mining, civil, and commercial operators across Australia and New Zealand since 2002.

We understand with in-field servicing, efficiency is key to a business's profits. We realise every minute of machinery downtime means money straight off the bottom line.

Which is why our Multiserve service trailers are engineered to meet each client's unique technical specs and servicing requirements, making them an ideal service solution for out in the field.

These trailers are designed and tested to ensure they deliver outstanding performance in even the harshest and most remote environments.



Contact us to discuss  
YOUR unique requirements!



**SHERMAC**  
Engineered Equipment  
Transitions

## PERFORMANCE. RELIABILITY. FLEXIBILITY.

Our service trailers have been designed to cater to every site situation, tank capacities can be configured to suit every application. This improves performance by having what you need on board, without carrying around excess product. Also a range of different products can be carried, such as; oils, diesel, coolant, and water.

We manufacture these vehicles with a range of primary power and delivery equipment, so regardless of your budget, and compliance requirements, the vehicle can be tailored to work for you. This flexibility means you can benefit from the performance of this product, while meeting your compliance, or budget limitations.

These service trailers have been designed to handle the toughest working environments. We extensively tested these units in Western Australia's Pilbara region, where the terrain is harsh, and distances between work sites can be immense.

These refined workhorses are really a true personification of our company credo "Driving Performance Capacity", making them the ultimate on-site service solution for small or large operations.



## APPEARANCE

Our Multiserve service trailers boast an aesthetically pleasing exterior, which adds value to your company image, and presents a professional image to the public.



## SECURITY

The trailer is completely enclosed, which provides security, and protection of the dispensing equipment from the elements, greatly improving durability.



## FLEXIBILITY

We custom design and manufacture mine-spec service trailers that deliver outstanding performance in the toughest mine environments. Available in 2,000; 3,000; 3,500 and 4,500 kilogram gross vehicle mass capacity.



## OPERATOR PROTECTION

One piece, top hinged doors provide the operator with shelter from the sun and rain.



Contact us to discuss  
YOUR unique requirements!

1300 799 943  
sales@shermac.com.au  
www.shermac.com.au

## POWER SUPPLY

Optional diesel powered generator sets to provide primary, or auxiliary power.



## WASTE OIL

Waste fluids system configured for evacuating, and out loading waste fluids direct from the machine. Also fitted with a drainage station for filters etc.



## PROMOTE YOUR COMPANY

Large spaces available for applying your company branding, making these trailers a mobile sign board.



## STORAGE

Easily accessible, secure storage area for filters and tools.



Contact us to discuss  
YOUR unique requirements!



**SHERMAC**  
Engineered Equipment  
Transitions

## MTS2000

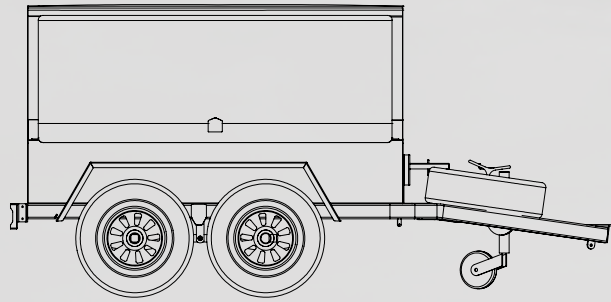
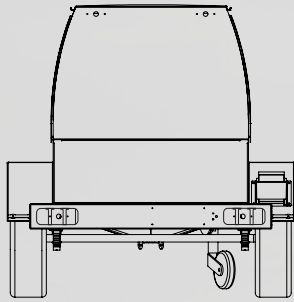

## MTS3500

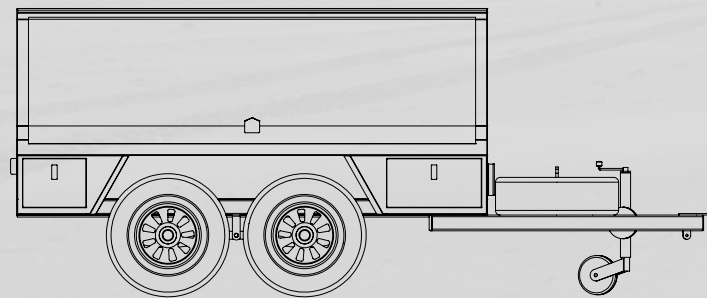
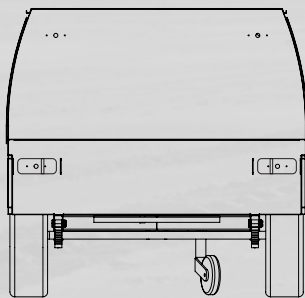

## SPECIFICATIONS

ITEM	MTS2000	MTS3500
Fully Self Bunded	S	S
Mechanical Overrun Brakes	S	N/A
Hydraulic Overrun Brakes	O	N/A
Electric Breakaway Brakes	O	S
Electric/Hydraulic Breakaway Brakes	O	O
245/75 R16 Off-Road Wheels	S	S
Land Cruiser 5 Stud Pattern	S	S
One Spare Wheel	S	S
Fluid Carrying Capacity (L)***	750	1750**
Diesel Powered Air Compressor	S	S
Petrol Powered Air Compressor	O	O
Air Powered Fluid Pumps	S	S
15 metre Spring Rewind Hose Reels	S	S
Diesel Powered Generator Set	O	O
Petrol Powered Generator Set	O	O
Standard Colour – White	S	S
Custom Paint Colour	O	O

S Standard | O Optional | \* Subject to towing capacity of towing vehicle | \*\* Based on 3500kg towing capacity of towing vehicle | \*\*\* Depending on equipment fitted



**Shermac Australia Pty Ltd**  
ABN 54 622 839 810

15 Deacon Street  
Dalwallinu 6609  
Western Australia

PO Box 414  
Dalwallinu 6609  
Western Australia

Freecall 1300 799 943  
Telephone 08 9661 2330  
Facsimile 08 9661 2300

[sales@shermac.com.au](mailto:sales@shermac.com.au)  
[www.shermac.com.au](http://www.shermac.com.au)

Driving Performance Capacity

